



# Care and Use Manual

## DigiPure 9000s

Information for the  
Proper Set-Up, Installation and Start-Up  
of the  
DigiPure 9000s Counter Top Filtration System  
with Upgraded Filtration Cartridge



**ALL PRODUCT FILTRATION PRODUCT  
MANUFACTURED AND ASSEMBLED IN THE USA**



**To the Consumer:  
Retain this Care & Use Manual for Product Registration and Future Reference**



## A Special Message to Our Customers,

EWS, Inc. and Environmental Water Systems would like to thank you for your consideration in selecting from our comprehensive list of residential filtration and conditioning product.

We recommend that you take the time to read the information that pertains to your product as you begin to use it.

The information in this manual is designed to assist you in the proper set-up, install and start-up of your system. In addition, the information contained in this manual is designed to provide the consumer, the most comprehensive information on this series of product.

Please contact us if you have any questions, comments or additions to the information provided.

Sincerely,  
Customer Service at EWS, Inc.



EWS, Inc. and Environmental Water Systems  
9101 W. Sahara Ave., Suite 105-J8  
Las Vegas, NV. 89117

Office: 702-256-8182 Available Monday through Friday, 8:30 - 4:30 Pacific Standard Time  
Fax: 702-256-3744 Dedicated and Available 24/7  
E-Mail: [customerservice@ewswater.com](mailto:customerservice@ewswater.com)  
Web Site: [www.ewswater.com](http://www.ewswater.com)

## Installation of the Filtration System

You may need the following for proper installation:

- Teflon tape
- Adjustable Wrench
- Pliers
- Work Gloves
- Safety Glasses
- Knife or scissors
- Pencil or something with a small point

**WARNING:** Verify that all components are included with the unit and were not lost, misplaced, or damaged in shipping or handling.

**CAUTION:** Do not attempt to install this system using defective or damaged components. Check and inspect, inlet and outlet fittings and any other connections on this system that might have been damaged during shipping and handling.



## Care and Use Manual - DigiPure 9000S Table of Contents

Registration Page	attached
A Message from EWS, Inc.	2
Installation of the Filtration System	
What you may need for proper installation	2
Verify and Inspect your system	2

### INSTALLATION OF THE WATER FILTRATION TREATMENT SYSTEM

Connection to the end of the faucet and adaptors	4
System Start-Up, Flushing, and Operation	5
Operating and Setting the Digital Flow Meter	6
Replacement of the Filter Cartridge	7
Disinfection Procedure	7
Systems Schematics and Parts Listings	8
Trouble Shooting Guide	9
Filter Replacement Information and Reference	
Upgraded GAC Filter Capabilities and GAC Filter Removal Capabilities	10
FDA, EPA and NSF Compliances	12
Warranty Information	13
Other Product for Various Applications	14

- Familiarize yourself with the system, its' replacement filter and maintenance.
- Understand your system's capabilities
- See your options in water treatment, for you , your family and your home by EWS, Inc.
- Register your system with our confidential data base and be reminded to replace your filters



## Making the Connection Unit Install and Set-Up

■ **Step 1: CONNECT THE DIVERTER TO THE END OF YOUR FAUCET**

**NOTE: YOU MUST HAVE A FAUCET WHERE YOU CAN REMOVE THE AERATOR**

Faucets may have different end pieces or aerators and may need a simple adaptor to fit correctly. Provided are 5 common adaptors to assist you. If these are not applicable to your situation, take the aerator and the diverter to a local hardware store and a professional can direct you to the correct adaptor for your situation.

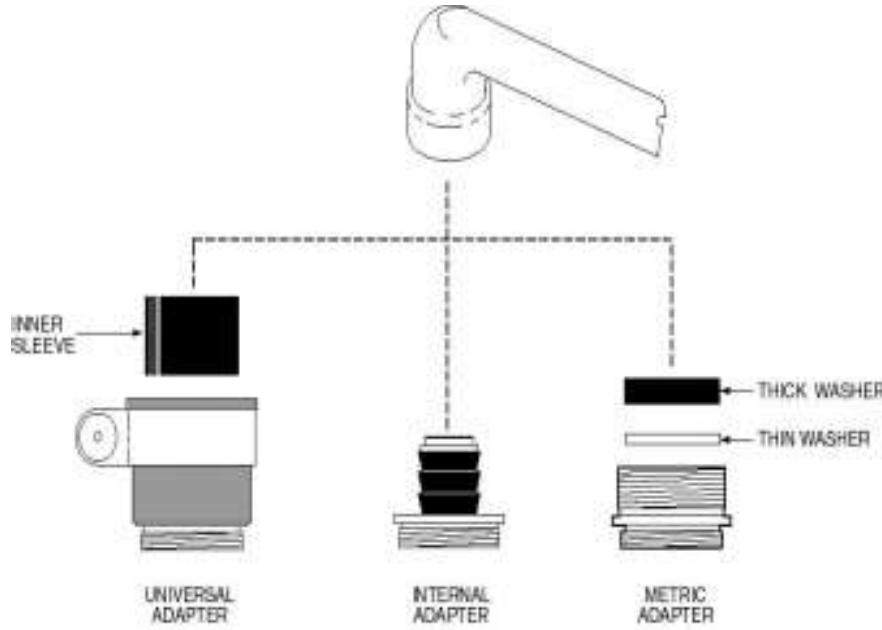
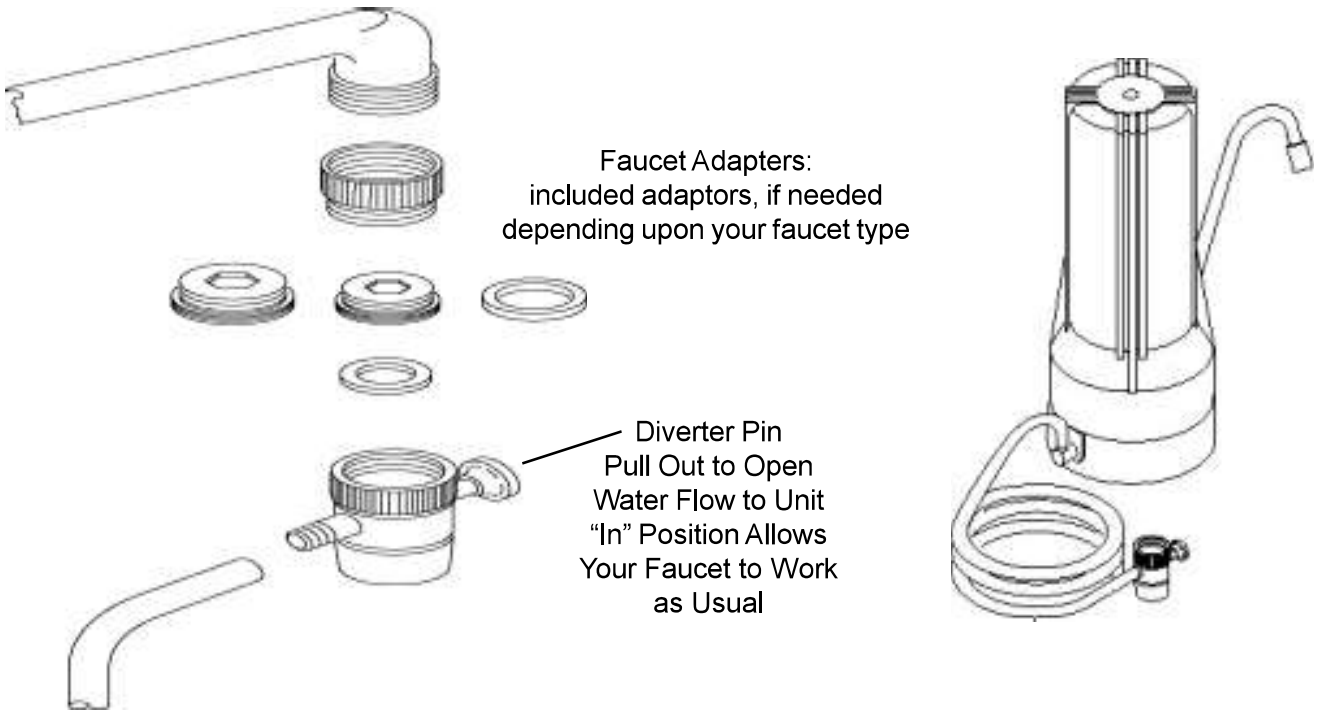

Other Faucet Adapters are Included with your purchase from Overstock.com

Depending upon your faucet type, you may need one of the following adapters.



## After the Connection Unit Start-Up and Operation

### ■ **START-UP AND OPERATION**

After the connection to your faucet has been made continue through the following steps:

#### **Step 2: Turn on Sink**

Turn on your sink faucet - cold side only. **WARNING: NOT INTENDED FOR SUPPLY BY HOT WATER.**

#### **Step 3: Turn on Unit**

Pull out Diverter Pin and lock in the open position to allow water to flow through unit. Water will begin to flow from dispenser/faucet and not from the sink faucet. Initially, water may sputter before full flow is achieved and water may be discolored until filter is flushed. Swivel the dispenser up or down, side to side to aim water flow where you want it. Make sure water is turned on full from sink.

**The digital meter will automatically display when there is flow through the water filter.**

Make sure the batteries are properly installed (included and installed with system). You will see a wave line indicating a flow of water. The first number to appear is (gal) the amount of gallons the capacity is set for. Press the Display key and the display will register the amount of flow through the filter in (g/m) gallons per minute. Press the Display key again and see (days) the number of days the time is set for.

**Note: See Setting the Digital Meter on the next page while Flushing Unit in Step 4.**

**Note:** The meter will automatically shut off in 10 seconds after water flow is shut off. No flow, no display.

#### **Step 4: Flush Unit**

Allow system to run steadily for approximately 2-3 minutes. This will wash all carbon fines and air from the system. End this flushing of the system once water runs clear. System is now available to use as normal.

**NOTE:** If you draw your water into a glass and it appears to be cloudy, it's only air and nothing bad. Let the glass sit and watch the air rise and dissipate. The filter cartridges used are full bed depth. The carbon (GAC) cartridges have a great deal of surface area. It may take 24-48 hours for this to correct itself.

#### **Step 5: Inspect Unit**

Inspect for leaks at all connections. If a problem exists, please shut off water supply to the system and consider the following solutions;

- Inspect for leaks at all system connections, such as the cartridge housing or your faucet connections

If there are any problems, please call or e-mail.

Please identify any damage in shipping or handling. You'll need to make a claim with the shipper, as indicated on your packing materials, the packing slip and the published terms of sale.

Please identify any problem and let us know if we can offer advice or a part that we can readily send you.

**WARNING:** Maximum pressure is 75 PSI. Pressure unregulated can surge or exceed the maximum rating on this and many items in the home. High pressure creates a water hammer or banging pipes. It's also the reason to use stainless hoses for washer machine connections and not the rubber. A pressure reducing valve (PRV) at your main water service line (if not code) is greatly recommended by many manufacturers' of many different household items, plumbing products and appliances.



## Setting the Digital Meter

**Read the following steps and notes first and then set your digital meter**

### Step 1: Setting the Digital Meter - Getting into the "system" (water does not have to be on)

Press and **Hold** Display Key, and using the point of a pencil (or something similar), Press Reset Key to enter into the setting procedure. *You must Press and Hold both Keys together.* The digit on the display will flash to notify you the setting procedure is on. Release the Display and Reset Keys and while the display is flashing begin the following steps.

**Note:** The Reset Key is a small hole. If your pencil point does not work (while Pressing Display Key), try again in a different position or angle into the hole until the display begins to flash. Sometimes it takes a moment. Setting procedure will stop and go back to the original setting, if there is no input for 10 seconds.

### Step 2: Setting the Digital Meter - Capacity Setting in gallons used before replacement

**To Change the Setting, if needed:** While flashing in gallons (gal), Press the Display Key to choose the Capacity Setting. The capacity display moves in intervals of 100 from 100-200-300.....to 19900-OFF-100-200-300. Press the Display Key to move the capacity to your gallon setting. Once you make your selection, using the point of a pencil, Press the Reset Key to save the setting. The time setting (day) will begin flashing, go to Step 3.

**Note on Capacity:** This is the amount of water that you will allow to go through the water filter before you change the cartridge. Consider the setting of a 1000 gallons, which is typically over a year of usage. The upgraded PB-1 filter used in this unit, has a capacity of 1500 gallons and the meter can be set for more or less, depending on personal preferences, concerns, and/or local water conditions. The capacity mode will be disabled when you choose OFF.

### Step 3: Setting the Digital Meter - Time Setting in days before replacement

**To Change the Setting:** While flashing in days, Press the Display Key to choose the Time Setting. The time display moves in 30-day intervals from 30-60-90.....to 720-OFF-30-60-90. Press the Display Key to move time to your setting (a year would be 360). Once you make your selection, using the point of a pencil, Press the Reset Key to save the setting. The setting procedure has been completed.

**Note on Time:** This is the amount of time that you will allow the water filter to operate before you change the cartridge. It is recommended this be done once a year or less, depending on personal preferences, concerns, and/or local water conditions. The time mode will be disabled when you choose OFF.

### Using the Automatic Flow Rate Meter

There is nothing to set. This information may determine cartridge life before the time and/or capacity meters warn you. When the water is flowing through the filter, Press the Display Key to change the current displaying status to flow rate (g/m).

For Example: When you first use your unit, with the sink turned on all the way for maximum flow rate, check the gallons per minute (g/m) of flow through the filter. When that flow rate is reduced in half it may be time to replace the cartridge even before the other meters and settings warn you to do so. Reduction in flow rate of 50% over time and gallons used indicates the filter cartridge is doing its' job and getting clogged and may be time for replacement.

### The Digital Meters' Alarms and Warnings

The digital meter will generate a beep sound when the capacity is less then 20 gallons and/or the time is at 7 days or less. Then, the digital meter will generate a beep-beep sound when the capacity in gallons is 0 and/or the time is 0 days.

Upon Filter Replacement: Using the point of a pencil, touch the Reset Key when the filter cartridge is replaced. This will go back to your previous settings. Adjust those settings as needed.

The digital meter will generate a beep sound and flash a battery sign in the display, when battery power is low. The sound and flashing sign will disappear upon replacement of fresh batteries. All your settings will be memorized when power is off.



## Replacement of the PB-1 Filter Cartridge

It is recommended that filters be changed at least annually (once a year) or more frequently based on usage (limit this cartridge to 1500 gallons) and local water conditions. The quantity and quality of the water processed effects the life of the filters. Adjust your digital meter for either amount of gallons and/ or an amount of time to pass before replacement.

**Step 1:**

Make sure inlet water supply and/or faucet to the system is off.

**Step 2:**

Place unit over sink, or a pan or towel should be placed under the housing to catch any water.

**CAUTION:** WATER WILL BE PRESENT WHEN FILTERS ARE CHANGED.

**Step 3:**

Hold base and turn housing counterclockwise to loosen. Remove housing.

**Step 4:**

Remove filter from housing and dispose.

**NOTE:** See disinfection procedure before replacing any filters.

**Step 5:**

Insert new filter, check o-rings, and seat into the base, then tighten housing by turning clockwise.

**WARNING:** The GAC filters have gaskets that must be seated and placed properly.

**CAUTION:** Inspect O-Ring for housing base. Make sure it is clean, free of any debris and not damaged or kinked. Make sure it is correctly seated into the channel at the housing base before replacement.

**Step 6:**

Upon Filter Replacement: Using the point of a pencil, touch the Reset Key when the filter cartridge is replaced. This will go back to your previous settings. Adjust those settings as needed.

**Step 7:**

**FOLLOW SYSTEM START-UP PROCEDURES FROM PAGE 7**



## Disinfection Procedure (optional)

This procedure may be performed at any time when changing filters or after extended periods of inactivity of the system.

**Step 1:** Follow Steps 1 through 4: Replacement of Filter Cartridge. Empty housing of the filter.

**Step 2:** Using chlorine bleach, measure 1/2 cup and pour into housing. Do NOT replace filter at this time.

**Step 3:** Turn unit upside down and replace housing and tighten. Take note of the housing O-Ring. Make sure water is off to prevent water flow. Shake around 30 seconds or more and then let sit for a minute.

**Step 4:** Open sink faucet, pull out diverter pin and lock in open position and allow system to completely fill and then run.

**Step 5:** Allow the water run for at least 5 minutes. **WARNING: DO NOT USE THIS WATER.**

**Step 6:** Now that the system has been disinfected. Re-open the housing as in previous procedures and wipe away any residual found to totally clean this system prior to new filter.

- FOLLOW STEPS 1 THROUGH 7 (from above): Replacement of Filter Cartridge
- FOLLOW STEPS 1 THROUGH 6 (from page 5): Unit Start-Up and Operation



Schematic for illustration purposes and parts information

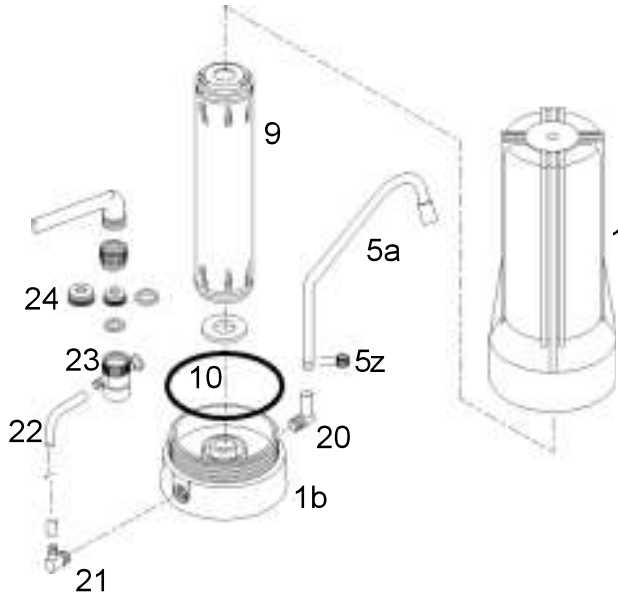

Parts Listing

Meter Base Specifications

Model #: DigiPure 9000s		
Schematic for illustration purposes only		
Ref#	Part	Description
1	h-filter-ct-DP	chrome housing for DigiPure
1b	DP-base	lower housing with meter - DigiPure
5a	fd-ct-ch-wh	Std chrome insert for counter w/wh, long reach
5z	fd-o-rings	o-rings at base of faucet, seal and swivel
9	PB-1	Upgraded GAC Block Filter Cartridge
10	h-f-o-ring	Housing base o-ring
20	fc-ct-fd	connection from base to insert dispenser
21	fc-ct-tconn	connection from base to tubing
22	t-ct-white	tubing for supply connection
23	fc-ct-diverter	faucet diverter
24	fc-ct-ad	faucet adaptors
	AAA batteries	Not Shown - two AAA batteries included

Model #: DigiPure 9000s	
Meters:	3
Capacity setting range:	100-19900 gallons
Timing setting range:	30 - 720 days
Flow rate range:	0.25 - 3.5 gpm
Accuracy:	+/- 5%
Sound alert:	yes
Reading:	gallons
Working temperature:	40 - 80°F
Working pressure:	20 - 75 psi
Power:	3 VDC, 2 x AAA battery
Cartridge support:	9 3/4"
Tube:	3/8" O.D. PVC

Exploded view: faucet adaption

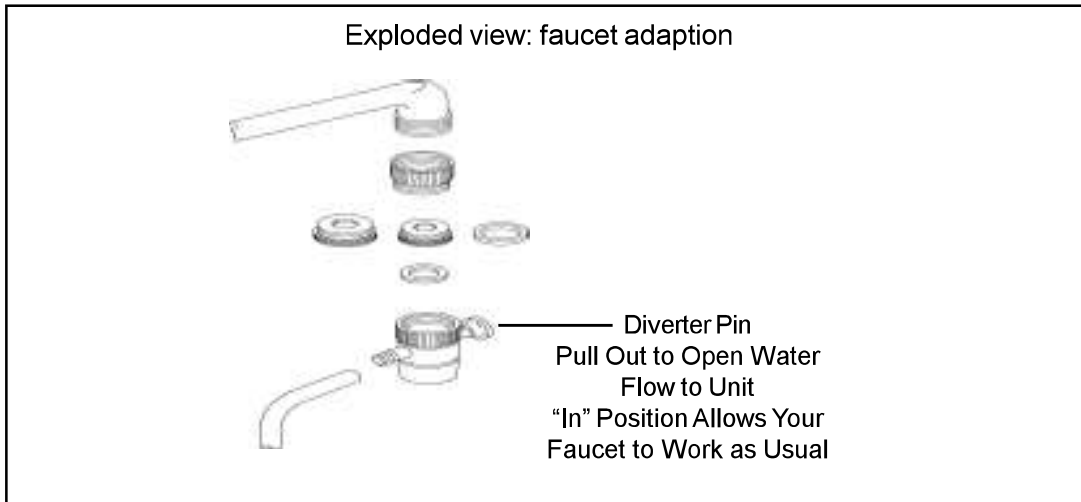



<b>Trouble Shooting Guide - Drinking Water Filtration Systems</b>		
<b>Problem</b>	<b>Possible Causes</b>	<b>Solution</b>
No water	Water supply is off	<ul style="list-style-type: none"> <li>•Turn main water supply on</li> <li>•Turn water on to the faucet</li> <li>•Pull Diverter Pin to open dispenser/faucet</li> </ul>
Not enough water	Low water pressure	Unit may not operate properly at less than 20 PSI feed line pressure (max: 75 PSI)
Leak at inlet or outlet fittings (undercounter drinking water systems only)	<ul style="list-style-type: none"> <li>•Is the tubing cut with a straight end to grab squarley?</li> <li>•Is the tubing inserted completely into fitting?</li> <li>•Is there a problem with the collet and the quick-connect fitting?</li> </ul>	<ul style="list-style-type: none"> <li>•Access the filter unit, remove tubing by depressing the collet and pulling tubing out. Using a utility razor knife, <u>squarely</u> cut 1/2" off tubing from the end. Make sure end of tubing is not flattened Reinsert the tubing into the fitting as far as possible. Check for leaks.</li> <li>•Tug on tubing (do not pull hard) to check fitting</li> </ul>
Leak at connections to, or between housings	Damage in shipping/handling	Call for part replacement, see parts listing
Leak at faucet or supply connections	Varied Causes, pull out dispenser and check o-rings and fit/insert	Check connections at various locations and re-connect, tighten, re-insert and/or correct
Leak at cartridge housing	Misaligned, damaged or missing O-Ring(s)	<ul style="list-style-type: none"> <li>•Locate and Align O-Ring into groove inside housing</li> <li>•Call for replacement housing o-ring part</li> </ul>
Any/all leaks	Excessive Pressure	Pressure reducing valve (PRV) at main water supply to maintain pressure at or below 75 PSI
Water Flow is Restricted	Kinked or Bent Tubing	Make longer loop with tubing to remove kink or bend
Unpleasant taste and/or odor Metallic flavor Discoloration Rotten egg smell from water	<ul style="list-style-type: none"> <li>•Need to replace filters</li> <li>•System needs disinfecting</li> <li>•System was idle, stored or misused for a long period of time.</li> <li>•System under unfavorable conditions or changing water conditions</li> <li>•Hydrogen sulfide, iron, manganese is in the household water supply</li> <li>•System misapplied</li> </ul>	<ul style="list-style-type: none"> <li>•Replace filters and follow start up procedures</li> <li>•Replace and disinfect: See instructions in this manual</li> <li>•Flush system by running water, replace filters and/or disinfect. See instructions in this manual</li> <li>•Determine what changed in your water supply and Flush, Replace and/or Disinfect, or change type of water treatment system based on local water conditions. Call your municipality or have your well tested.</li> <li>•Hydrogen sulfide, iron and manganese must be removed from household water supply before filter system. Visit our web site and see the Pyrolox systems</li> <li>•The wrong system for the application</li> </ul>
Cloudy water	<ul style="list-style-type: none"> <li>•New installation, changing filters, disinfecting the system</li> <li>•Open/close and open of water supply to home or in home</li> </ul>	It is simply - air. Check by filling glass and watch air dissipate. Run and flush system for several minutes. Sometimes it takes 24 - 48 hours to totally clear due to the full bed depth of our filters
Electronics	Limited to display, power or damage	Make sure batteries are properly installed and are fresh and have a charge. Follow instructions to reset display and to properly set meters. Call for assistance



## PB-1 Upgraded GAC Filter Cartridge

### Extruded Activated Carbon Block Filter

In use with your DigiPure 9000s

The PB-1 cartridge meets or complies with NSF Standard 53 for the removal of Lead and Cysts (Giardia, Cryptosporidium) in addition to removal of Chlorine and other Volatile Organic Compounds. See GAC reference chart on opposite page for additional capabilities

- Lead Reduction: 2,500 gallons @ 0.75 GPM
- Cyst Reduction: Giardia, Cryptosporidium
  - >99.96% reduction of 1 - 2  $\mu$ m particulates
  - >99.984% reduction of 3 - 4  $\mu$ m particles
- Class 1 Turbidity Reduction
- Outstanding Chlorine, Taste and Odor Reduction
- Chlorine Reduction >90 % @ 6,000 gallons @ 0.75 GPM

Filter Dimensions: 2.50" O.D. x 1.25" I.D. x 10" L  
Carbon Weight: 0.85 lbs. Iodine No. 1100

Construction:  
Precision Continuous Extrusion,  
Graded Density Pre-Filtration Design

#### Lead and Heavy Metal Reduction

##### Reduction of Soluble and Insoluble (Particulate) Lead

The PB-1 extruded activated carbon filters reduce soluble lead using an ion-exchange filter medium with high specificity for soluble lead. Particulate filtration is used to intercept insoluble lead-containing particles. Standard 2.50" O.D. x 9.75" L filters will reduce lead, a minimum of 90% (or 150 ppb) over 2,500 gallons @ 0.75 gpm meeting NSF test protocol for Standard 53.

#### Chemical Adsorption

PB-1 filters offer high levels of chemical reduction in potable drinking water, including the removal of chlorine and other compounds that contribute to taste and odor.

#### Particulate, Cyst and Turbidity Reduction

PB-1 filters provide >99.984% reduction of 3-4  $\mu$ m particulate, >99.96% reduction of 1-2  $\mu$ m particulates, and are high performance sediment filters with extended life. Graded-density prefiltration combined with high dirt capacity extruded activated carbon provide several times greater life than molded filters.



PB-1 filters consist of activated carbon particles fused into a uniform block with enhanced adsorptive capacity and efficiency. These filters flow in a radial, outside-to-inside direction, providing increased dirt capacity and low pressure drop. Unlike more basic GAC filters, these cartridges will not channel or by-pass, due to extreme uniformity of the extruded activated carbon core. Service life of the PB-1 is greatly extended by two layers of prefiltration media consisting of 15  $\mu$ m polypropylene spun-bonded outer pre-filtration layer and a 5  $\mu$ m polypropylene melt-blown inner layer.

**Caution:** Filters or media representing percentages of removal "up to" do not provide the minimum removal rate or the quantitative amount that can actually be removed. In addition, any removal may be over a limited amount of water and may meet only the minimum of the standard for that filter. Better marketing does not provide better consumer protection.

In addition to the detailed and technical information provided about this filter cartridge, please review the GAC Reference, the basic characteristics of carbon filtration regarding the removal of chlorine and other disinfectants, as well as, volatile organic containments (VOC's).



In addition to the detailed and technical information provided about this filter cartridge, please review the GAC Reference, the basic characteristics of carbon filtration regarding the removal of chlorine and other disinfectants, as well as, volatile organic containments (VOC's).

GRANULAR ACTIVATED CARBON (GAC) Reference List

Below is a simple reference chart to give some perspective as to GAC's capabilities with various substances. Some items are heavy metals and inorganics, while others are VOC's (volatile organic compounds), some of which are man-made pollutants. Still other items, such as hardness, are not even considered contaminants. In general, GAC is very economical and a great compliment to municipally-treated water without the disadvantages of more aggressive filtration. GAC is used in all filtration due to its removal capacities. Know your water to select the correct product for you, your family and your home.

Table with 5 columns listing various substances and their corresponding GAC removal ratings (0-5).

KEY TO THE ABOVE LIST:

- 5- EXCELLENT - A proven application 4- VERY GOOD - A proven application 3- GOOD - very acceptable result 2- FAIR - limited application 1- POOR - not a recommended application 0- Not an application for GAC

Well water or municipally-treated water with issues related to inorganics, heavy metals or items above that GAC is fair to none (2-0) are generally issues reverse osmosis systems treat better then GAC alone. See our complete selection of reverse osmosis product and apply only when necessary due to drawbacks associated with these units.



## FDA, EPA and NSF Compliances

**1) Please be advised all the materials and components utilized in producing these POE (whole home) and POU (sink) filtration, drinking water, and reverse osmosis systems comply with, but not limited to, one or more of the following regulating standards:**

NSF STANDARD 14	FDA 21 CFR 177.1520	FDA 21CFR 177.1640	FDA 21 CFR 177.1350
FDA 21 CFR 175.105	CAS # 7440-44-0	ANSI 304	CDA C360000
NSF STANDARDS 60 AND 61	NSF STANDARD 58	ANSI 302	ANSI 316
FDA 21 CFR 177.2600	FDA 21 CFR 175.300	FDA 21 CFR 177.2550	NSF STANDARD 52
NSF STANDARD 42	NSF STANDARD 18	FDA 21 CFR 177.2550	FDA 21 CFR 177.1655
FDA 21 CFR 177.1630	FDA 21 CFR 177.2800	FDA 21 CFR 175.300	FDA 21 CFR 177.2260
FDA 21 CFR 181.32	FDA 21 CFR 177.2660	FDA 21 CFR 177.1950	FDA 21 CFR 177.2910
FDA 21 CFR 177.2250	FDA 21 CFR 177.1680	NSF STANDARD 53	NSF STANDARD 55

**Most of these standards relate to the Code of Federal Regulations of the United States of America, Title 21, Charter 1, Subchapter B set forth by the U.S. Food and Drug Administration. The NSF (National Sanitation Foundation) standards correlate to materials and potable water.**

**2) Without exception every component included in any and/or all of our systems are compliant for food and beverage contact and/or meet or comply with the most current appropriate and applicable standards without exception.**

### 3) Performance Guidelines:

Follow EWS, Inc. detailed installation, start-up and maintenance instructions and follow all local plumbing codes. The feed water must comply with the following conditions for the system capabilities, compliances and warranties to remain valid.

- Water Temperature Range: 40-80°F; Water Pressure: 40-75PSI; All systems must be connected to main or cold water supplies (hot water not to flow through systems). Units always contain water-Do not allow unit to freeze.Do not use where water is micro-biologically unsafe or with water of unknown quality without adequate disinfection before or after the unit.

- Reverse Osmosis Systems Only - Never allow reject water to be stopped, without the reject water flow or improper drain connection impurities may build up on membrane. POE Units - Do not prevent backwash or brine lines to be stopped or restricted.

### 4) Factory Preparation:

All systems are factory prepared and checked to assure proper function and if applicable, quality tests of product water produced to assure that minimum standards of rejection have been met, tests of specific components to assure correct function and flow rate measurements to assure efficiency specifications are met.

### 5) Know your water:

- If on a municipal system, large or small, it is your right as a consumer to have access to the most recent test results and to expect adherence to federal guidelines, as well as, any state or local requirements. Any problems should be reported to the appropriate agencies. Please acquire those municipal test results to become an informed consumer.

- If on your own individual well, have your water completely and independently tested. Local code may require a simple test for coliform bacteria to approve a well, however you may be unaware of potential problems for you and/or your home. Review our section on well water testing and applications in our complete catalog or visit our website.

The contaminants or other substances removed or reduced by these and other water filtration devices are not necessarily in your water. Performance may vary based on local water conditions. To confirm the presence of any contaminants, have your water supply analyzed by an independent and approved facility. Not intended for use where water is microbiologically unsafe or with water of unknown quality without adequate disinfection before or after unit(s). To ensure proper operation, follow installation procedures. Filter maintenance schedule will vary and must be replaced, as necessary, as determined by usage and local water conditions. Contaminants and/or constituents, primary and secondary and aesthetic aspects of water, as known and acknowledged by the EPA and The Clean Water Act, will be the only basis with which test results and information will be accepted and validated.

Proper application (systems being used for the correct reason), setup, installation, startup and maintenance are crucial to insure proper water quality and warranties. Taste and aesthetics are personal and subjective.

**See additional information for all filtration removal capabilities, r.o. rejection rates and system tolerances.**



## Limited Warranty

Limited Warranty: EWS, Inc., a Nevada corporation, hereby warrants all products to the original consumer purchaser to be free from defects in material and workmanship as stated in the following paragraphs, and as may be addressed in General Terms and Standard Conditions of Sale in the following:

All Point of Use; counter, undercounter, shower, residential reverse osmosis and softener units or systems for one (1) year from date of purchase. All Environmental Water Systems, pyrolox units, pH increasing reagent tanks and whole-home basic filtration systems for 10 years on the tank and the ICN conditioner (if applicable) and three years on the valve head. Filtration media and/or cartridges are not covered by warranty. Contaminants or other substances removed or reduced by any water treatment system are not necessarily in your water. Performance may vary based on local water conditions. To confirm the presence of any contaminants, have your water supply analyzed by an independent and approved facility. Not intended for use where water is microbiologically unsafe or with water of unknown quality without adequate disinfection before or after units. To ensure proper operation, follow installation procedures. Filter replacement schedule will vary and must be replaced, as necessary, as determined by usage and local water conditions.

EWS, Inc. will replace, free of charge, during the warranty period, any part which proves defective in material and/or workmanship under normal installation, use, service and proper care as mentioned in our detailed instructions, which can be obtained by a local dealer, distributor, representative or direct from EWS, Inc. and/or our web address; [www.ewswater.com](http://www.ewswater.com). Replacement parts can be obtained from your local dealer or distributor. This warranty is the exclusive warranty granted by EWS, Inc. and is in lieu of all other warranties of merchantability and fitness for a particular purpose and is further limited to defective parts replacement only. Labor charges and/or damage incurred in installation, repair or replacement as well as incidental and consequential damages connected there with are excluded and will not be paid by EWS, Inc.

Purchaser's responsibility is to keep your purchase receipt and/or installation receipt; failure to do so voids the warranty. If applicable, Purchaser should fill out any registration forms and register Product by telephone, fax and/or e-mail to designated address to obtain information and updates. To obtain warranty service, contact your local dealer or plumbing contractor or write to EWS, Inc., Customer Service or e-mail to; [customerservice@ewswater.com](mailto:customerservice@ewswater.com). EWS, Inc. to cover warranty service for 90 days from date of installation. A follow-up or check of any system install and operation by any persons, is not covered under any warranty, unless it has been determined there is an issue covered under warranties of product materials and workmanship. Under no circumstances will EWS, Inc. cover any service or warranties, in that or any time period, that has resulted from improper application, poor handling, set-up, installation, start-up procedure and/or lack of thorough follow through of installation procedures found on the unit and in all service guides, product manuals and websites.

This warranty is void for any damages due to misuse, abuse, neglect, accident, improper handling, set-up, installation, and/or start-up or any violation of instructions furnished by EWS, Inc. or any replacement parts other than genuine parts supplied by EWS, Inc.

Any problems of water quality, and/or fitness of any EWS, Inc. product associated with any mechanical, construction, application and/or environmental issues (ie: flow rates, high or low PSI, piping materials, broken supply lines, changing water conditions; well or municipal water quality, et. al.), known or unknown, of the home or facility will not be considered by EWS, Inc. until such issue(s) have been resolved. Taste and aesthetics may be a personal issue and are strictly subjective and not related to the performance of any system.

Consumer must look to themselves, their builder contractor, the plumbing sub-contractor and any other installer of choice for the proper installation and application of any device manufactured by EWS, Inc. (or any other product for that matter). Items do not specify and/or install themselves. EWS, Inc. has provided many sources to acquire information on proper application of systems and their installation prior to any purchase. EWS, Inc. manufactures a complete product line of point of use water filtration systems and point of entry filtration, softening and/or conditioning systems and/or appliances. EWS, Inc. and the distributors of EWS, Inc. will stand behind the warranties of materials and workmanship, however EWS, Inc. and the distributors of EWS, Inc. and the Environmental Water Systems Product Line does not bear any responsibility for improper applications of product and/or improper installation. It is for this reason that EWS, Inc. provides complete information for your understanding, specification and selection, and proper application and installation.

EWS, Inc. 06/83, 09/99, 01/03